

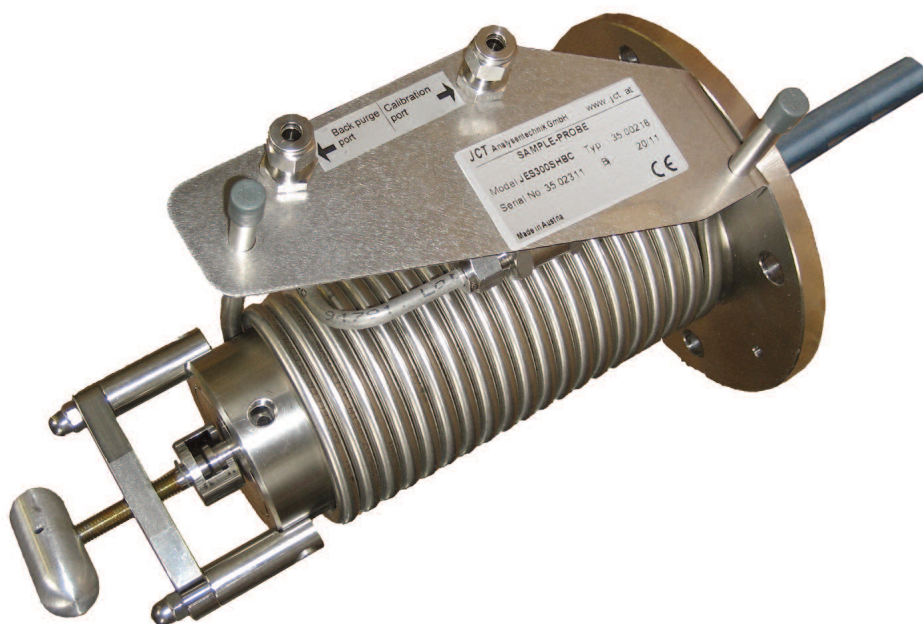

JCT
Analysentechnik

JES-301G

Steam Heated Gas Sampling Probe



Gas Sampling Probes

Heated Sample Lines

Sample Gas Coolers

Condensate Treatment

Accessories

Gas Conditioning Systems

Sample Gas Converters

APPLICATION

- Representative continuous gas sampling in processes containing dust and humidity
- Extended temperature range for extreme ambient conditions
- Extractive gas analysis
- Emission (CEMS) and process monitoring
- Removal of dust from the sample gas
- Suitable for safe area and EX area

BENEFITS

- Heated without electrical power supply
- Convenient filter replacement
- Low maintenance
- Safe unattended operation
- Easy start-up
- Even for high dust concentrations
- Reliable protection of the analyzer system

FEATURES

- Temperature control by steam pressure
- Large active filter surface
- Filtration from outside to inside
- Filter element change without tools
- Different material of filter elements
- Weather protection housing (option)
- Various options and upgrades
- Wide range of accessories
- Full bore ball valve for process shut-off (option)
- Manual and actuator operation of ball valve (option)

DIMENSIONS

Dimensions in mm

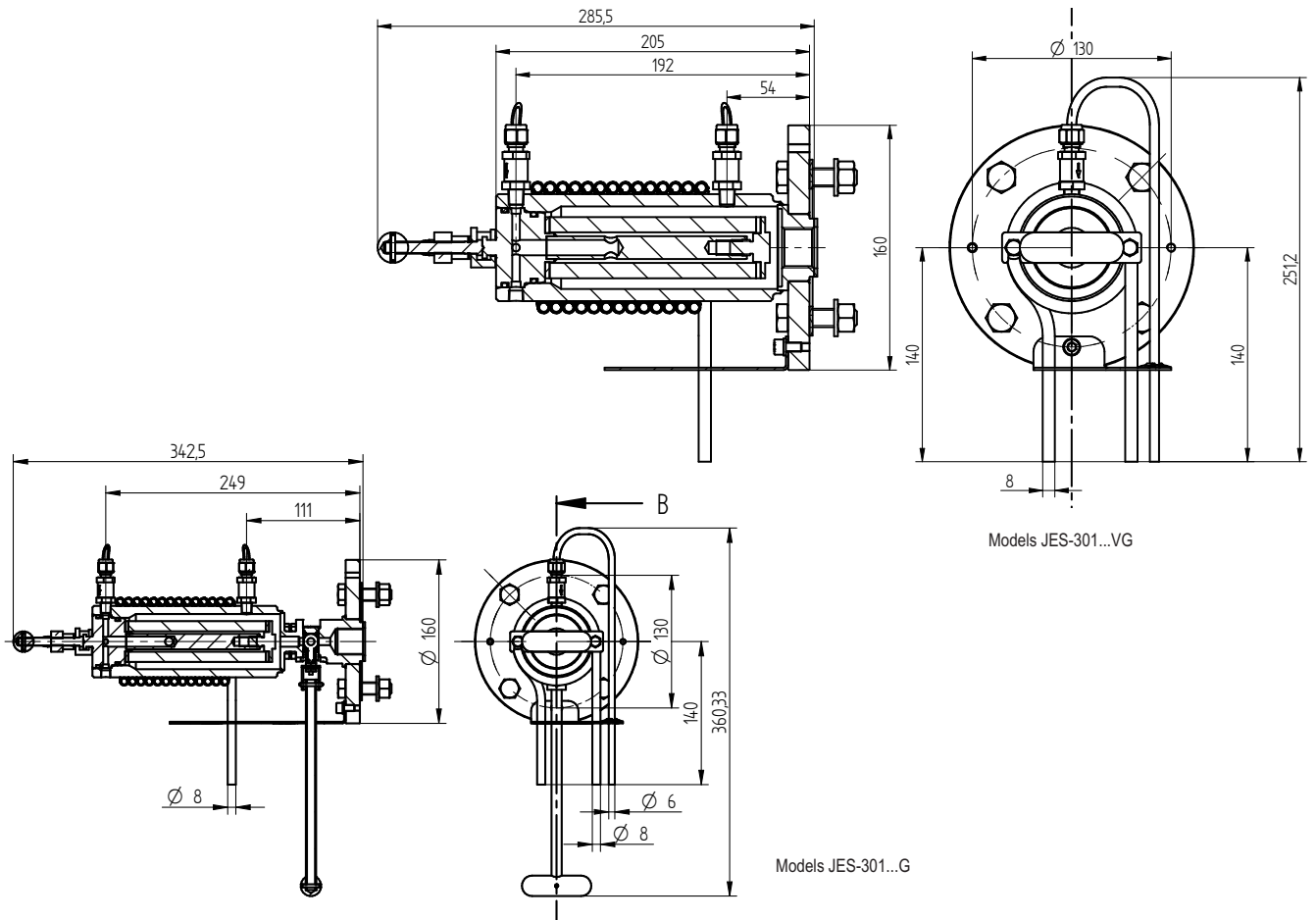

ORDER CODE

Model	Filter		Options			Flange	
	2 µm ceramic	0,2 µm ceramic coated	Back purge port *1	Calibration port *1	Steam heated	DN65/PN6	2" ANSI (Z)
JES-301G	X				X	35.00240	35.00250
JES-301BG		X	X		X	35.00241	35.00251
JES-301CG	X			X	X	35.00242	35.00252
JES-301BCG		X	X	X	X	35.00243	35.00253
JES-301GV	X				X	35.00244	35.00257
JES-301BGV		X	X		X	35.00245	35.00254
JES-301CGV	X			X	X	35.00246	35.00255
JES-301BCGV		X	X	X	X	35.00247	35.00256

Scope of delivery: sampling probe, mounting material, flange gasket, gasket for sampling pipe, operating manual
 *1...with non-return valve

TECHNICAL DATA

Model

JES-301G

Description	stationary steam heated gas sampling probe
-------------	--

Operation

Temperature	max. 200°C (corresponds to 14 barg of superheated LP steam)
Operating pressure	max. 2 bara (max.7 bara optional)
Operating pressure (steam pipe)	max. 40 bara
Mounting position	5° to 15° incline (recommended), torsion angle max. 45°
Ambient temperature	-40°C to 80°C

Construction

Dimensions over all (W x H x D)	160 x 251 x 286 mm
Dimensions over all with process shut-off valve (W x H x D)	160 x 360 x 343 mm
Filter element	2 µm ceramic or 0,2 µm ceramic coated
Active filter surface	170 cm ²
Mounting flange	DN 65, PN6; form A according to EN 1092-1; SS316L or 2" ANSI 150 lbs; according to ASME B16.5
Sample gas inlet	G 3/4" female thread
Sample gas outlet	1/8" NPT female thread
Steam ports	pipe 8 mm, SS316
Calibration gas connection (option)	pipe 6 mm, SS316
Back purge connection (option)	pipe 6 mm, SS316
Process shut-off valve (option)	temperature max. 200°C at 7 bar
Gas wetted materials	SS316L, ceramic, Viton®
Weight	7 kg
Approvals / signs	CE

GAS FLOW DIAGRAM

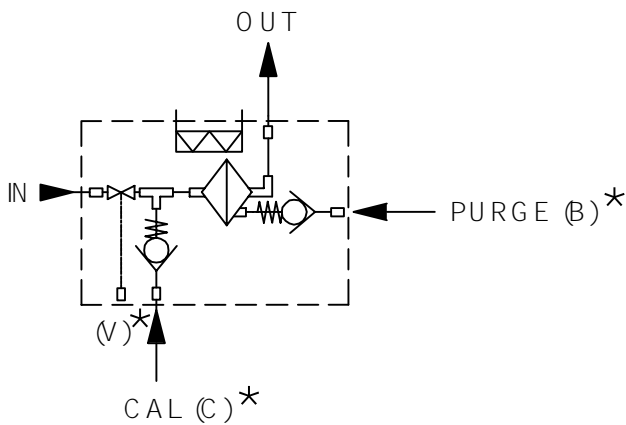

*... not included in all models

**Pressure characteristics in dependence of the gas flow
(for new filter element and 20 °C)**

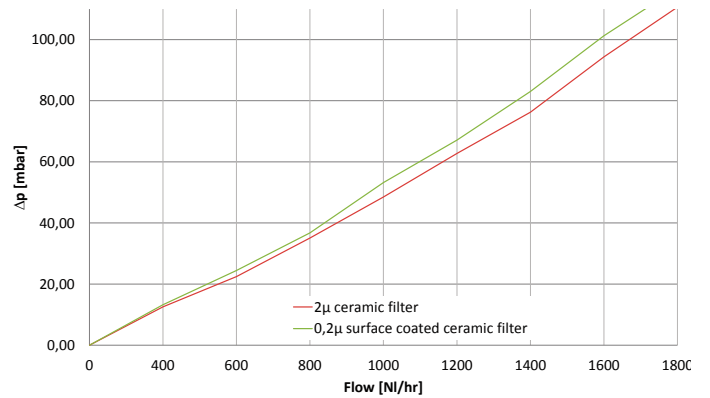

ORDER CODES FOR UPGRADE OPTIONS AND ACCESSORIES

Upgrade Options

35.00682	High temperature version up to 315°C for DN 65, PN 6 flange
35.00683	High temperature version up to 315°C for 2" ANSI flange

Stainless Steel Housing, SS304

35.00249	Housing for DN 65, PN 6 flange
35.00259	Housing for 2" ANSI flange

JCT Analysentechnik GmbH offers a wide range of accessories. Please refer to separate data sheets for further information:

- **JER Sampling Pipes and JHD Pre-Filters**

Sampling pipes in various materials and lengths

In-Situ pre-filter in various materials

Extension pipes in various materials

- **JES-301K Back Purge Control Unit**

- **JES-301 Accessories**

Flange adapters

Accessories for gas connections

Accessories for heated sample pipes

Gas Sampling Probes

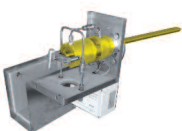

Heated Sample Lines



Sample Gas Coolers



Gas Conditioning Systems



NOx Converter



and solutions for

