



JHPF Heated Adapter Pipe

JCT
Analysentechnik



Gas Sampling Probes

Heated Sample Lines

Sample Gas Coolers

Condensate Treatment

Accessories

Gas Conditioning Systems

Sample Gas Converters

APPLICATION

- Extractive gas analysis
- Emission and process monitoring
- Process external heating of pre-filters for applications with high dust concentrations combined with high process temperatures (above maximum temperature of pre-filter)
- Combinable with gas sampling probes JES-301 and JES-301L

BENEFITS

- Sampling without influence on the sample gas
- No corrosion due to condensate formation
- Uniform reliable heating of the pre-filters independent of the operating conditions
- Cleaning via back purge connection
- Easy mounting
- Safe operation

FEATURES

- Corrosion resistant stainless steel pipe
- Fully electronic temperature controller with low temperature alarm and excess temperature switch-off
- Error message for sensor short-circuit and broken sensor
- Mounting directly at the standard process and gas sampling probe flange
- Pipe length 400 mm
- Temperature adjustment range 5°C to 200°C, optionally 5°C to 320°C
- Sampling pipes of arbitrary length can be screwed in on process side
- Back purge connection with check valve

TECHNICAL DATA

Model

JHPF

Description	heated adapter pipe for heating of process external pre-filters
-------------	-----------------------------------------------------------------

Operation

Operating temperature	5°C to 200°C adjustable (ex works 180°C) optionally: 5°C to 320°C
Ambient temperature	-20°C to +60°C
Operating pressure	max. 2 bara (7 bara optional)
Mounting angle	5° to 15° incline (recommended)
Mounting position	torsion angle max. 45°
Flow back purging	approx. 4 Nm ³ /h at 5 bara, 5 Nm ³ /h at 7 bara
Heating-up time	approx. 30 min
Status alarm	temperature: ± 20K to set point, sensor short circuit, broken sensor

Construction

Dimensions over all (W x H x D)	160 x 317 x 400* mm
Dimensions connection box (W x H x D)	120 x 160 x 90 mm
Mounting flange**	DN65 PN6 form A according to EN 1092-1, SS316; 2" ANSI 150 lbs optional
Sample gas wetted materials	SS316L, SS316
Protection class	electronic: IP65, adapter pipe: IP43 (EN60529)
Weight	approx. 12 kg
Housing material and colour	aluminium, natural
Connection sample gas inlet	G 3/4" f
Connection back purging	1/8" NPT
Approvals / signs	CE

Electrics

Power supply	230 VAC 50/60 Hz or 115 VAC 50/60 Hz
Electrical connection	terminals 0,08mm ² to 2,5 mm ²
Cable entry	M20 x 1,5 (power supply), M16 x 1,5 (status contact)
Power heating element	500 W
Power consumption	approx. 515 VA
Temperature controller	fully electronic
Accuracy	± 2K
Temperature sensor	two wire PT100, class B
Status contact	volt free change over contact, 230 VAC / 2 A, min. 5 VADC / 5 mA
Fusing	lead fuse T6, 3 A / 230 VAC
On time	100 %
Diagnostic / operation indicator	3 x LED

* Other pipe length on request

** For other process flanges flange adapters for e.g. 2,5", 3", DN80 PN6 or DN100 PN25 are available

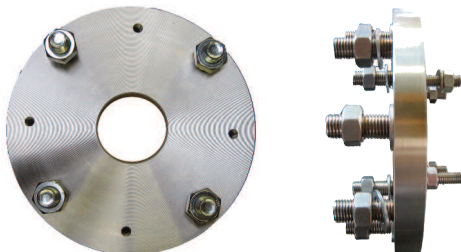

DIMENSIONS

Dimensions in mm

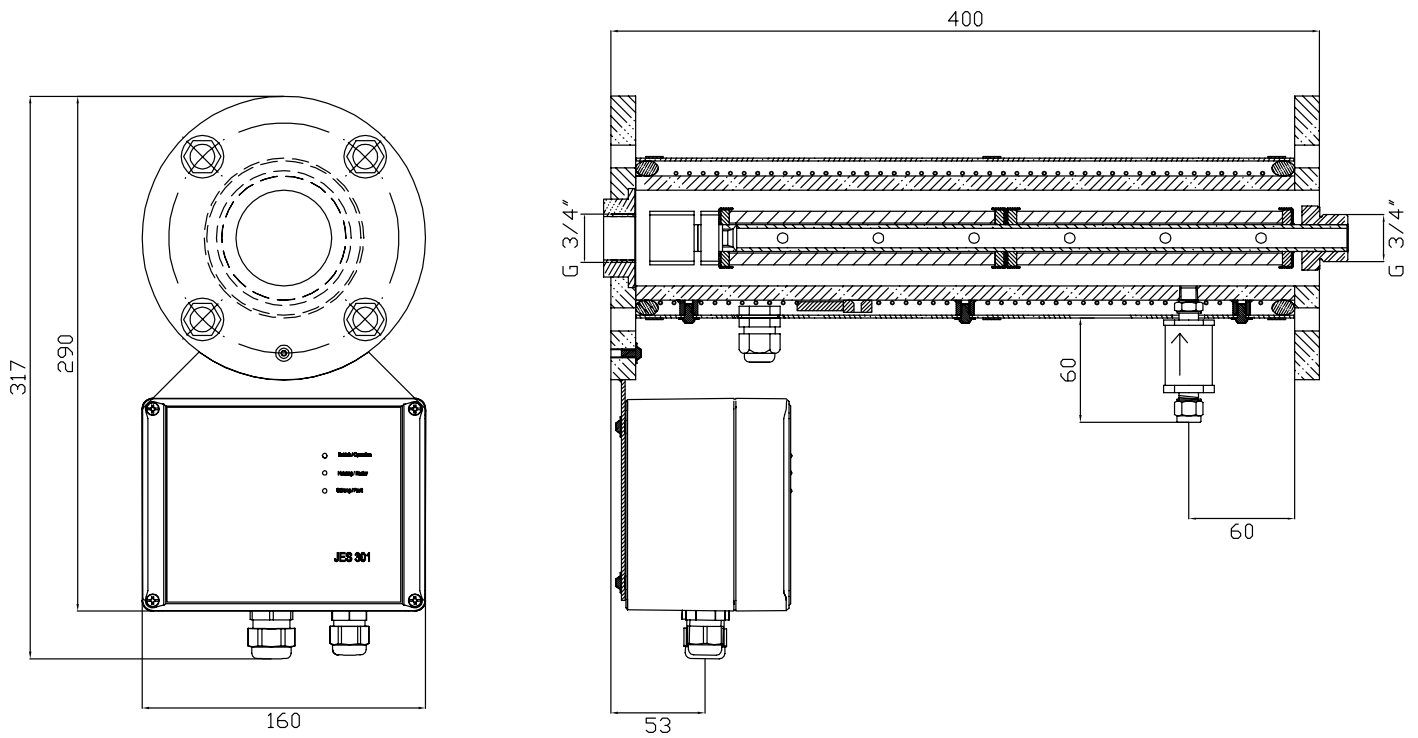

MOUNTING EXAMPLE

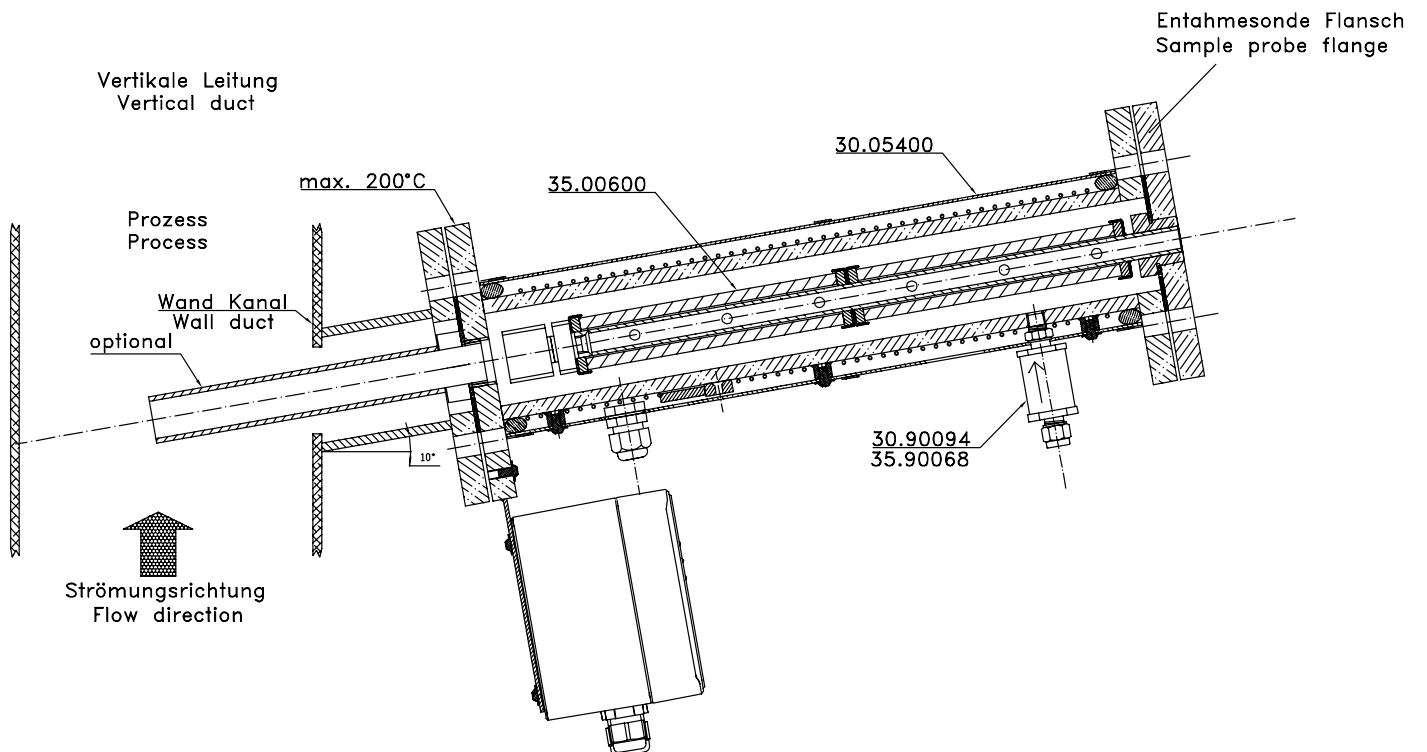

ORDER CODE

Order code	Description
35.05400	Heated adapter pipe with back purge valve, 200°C, 2 x mounting flange DN65 PN6, 230 VAC 50/60 Hz
35.05401	Heated adapter pipe with back purge valve, 200°C, 2 x mounting flange DN65 PN6, 115 VAC 50/60 Hz
35.05402	Heated adapter pipe with back purge valve, 320°C, 2 x mounting flange DN65 PN6, 230 VAC 50/60 Hz
35.05403	Heated adapter pipe with back purge valve, 320°C, 2 x mounting flange DN65 PN6, 115 VAC 50/60 Hz

ORDER CODES FOR ACCESSORIES

Order code	Description
35.90094	Non-return valve 1/8" Viton®, 200°C
35.90068	Non-return valve 1/8" Kalrez®, 320°C
35.90141	2 l air accumulator, panel mounting
35.90142	5 l air accumulator, panel mounting
35.90143	10 l air accumulator, panel mounting

Pre-filter, ceramic, max. 200 °C (320 °C optional), 16 µm, Ø 34 mm m

Order code	Designation	Length [mm]	Description
35.00600	JHD-JHPF	2 x 150 mm	Two-piece ceramic pre-filter with stainless steel mounting for change of the filter elements, gaskets Viton®, filter surface 282 cm², connection G3/4"a



JCT Analysentechnik GmbH offers a wide range of accessories. Please refer to these separate data sheets for further information:

- **JER Sampling Pipes and JHD Pre-Filters**

Sampling pipes in various materials and lengths

In-Situ pre-filter in various materials

Extension pipes in various materials

- **JES-301 Accessories**

Flange adapters

Accessories for gas connections

Accessories for heated sample pipes

Gas Sampling **Probes**

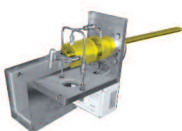

Heated Sample **Lines**



Sample Gas **Coolers**



Gas Conditioning **Systems**



NOx **Converter**



and solutions for

