



JCT
Analysentechnik

JSR-25 Condensate / Dosing Pump



Gas Sampling
Probes

Heated Sample
Lines

Sample Gas
Coolers

Condensate Treatment

Accessories

Gas Conditioning
Systems

Sample Gas
Converters

APPLICATION

- Extractive gas analysis
- Emission and process monitoring
- Continuous condensate removal, e.g. at **JCT** sample gas coolers
- For mounting in gas conditioning systems and in sample gas coolers
- Combinable with condensate pre-separators

BENEFITS

- Sure continuous condensate removal
- High operational safety
- Sufficient pump capacity for nearly all applications of continuous gas analysis
- Easy mounting and integration in gas analysis systems
- Long lifetime
- Low and easy maintenance effort
- Corrosion resistant
- Gas tight

FEATURES

- For continuous operation
- Condensate pump capacity approx. 290 ml/hr at low speed
- Dosing pump capacity approx. 12 ml/hr at low speed
- Self suctioning
- Corrosion resistant materials
- Consisting of synchronous motor, transmission and pump
- Double roll bearing
- Two PVDF-hose fittings for hoses DN 4/6
- Available with or without housing
- Easy to maintain design

TECHNICAL DATA

Model	JSR-25	JSR-25 in housing
Description	continuous working peristaltic pump for condensate removal	
Operation		
Flow rate	condensate pump approx. 290 ml/hr / dosing pump approx. 12 ml/hr	
Ambient temperature	+5°C to 40°C	
Operating pressure	0,2 to 2,2 bara	
Construction		
Dimensions over all (W x H x D)	80 x 105 x 93 mm	80 x 144 x 134 mm
Weight	approx. 0,5 kg	approx. 0,7 kg
Connections inlet / outlet	PVDF-hose fitting DN 4/6 mm	
Media wetted materials	PVDF, Novoprene	
Protection class	IP20	IP52
Mounting	in systems / on panels	wall mounting
Electrics		
Power supply	115/230 VAC 50/60 Hz	
Power consumption	5 VA	
On-time	100 %	
Electrical connections	spring type terminals 1,5 mm ²	spring type terminals 1,5 mm ² , cable gland M16 x 1,5 mm, clamping range 3 to 9 mm

DIMENSIONS

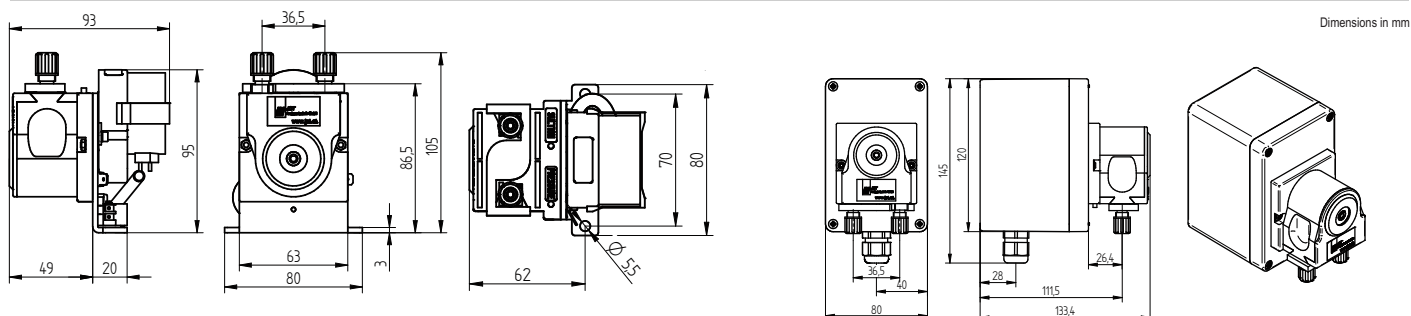

ORDER CODES

Order code	Description
32.00530	JSR-25 condensate pump in Makralon® housing, 115/230 VAC 50/60 Hz, 5 rpm
32.00510	JSR-25 condensate pump without housing, 115/230 VAC 50/60 Hz, 5 rpm
32.00535	JSR-25 condensate pump in Makralon® housing, 115/230 VAC 50/60 Hz, 10 rpm
32.00515	JSR-25 condensate pump without housing, 115/230 VAC 50/60 Hz, 10 rpm
32.00560	JSR-25 dosing pump in Makralon® housing with hose fitting, 115/230 VAC 50/60 Hz, 1 rpm
32.00550	JSR-25 dosing pump without housing with hose fitting, 115/230 VAC 50/60 Hz, 1 rpm

Gas Sampling **Probes**

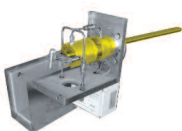

Heated Sample **Lines**



Sample Gas **Coolers**



Gas Conditioning **Systems**



NOx **Converter**

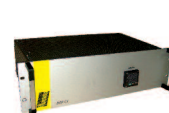

and solutions for

