

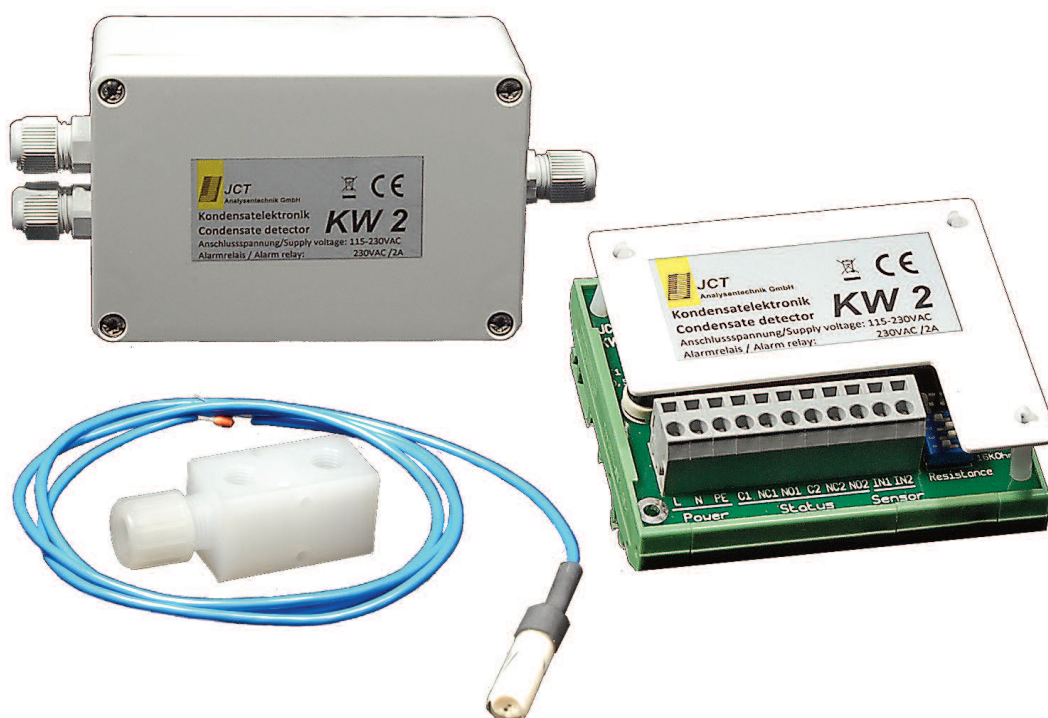

**JCT**  
Analysentechnik

# KW-2 Condensate Detector



Gas Sampling  
Probes

Heated Sample  
Lines

Sample Gas  
Coolers

Condensate Treatment

Accessories

Gas Conditioning  
Systems

Sample Gas  
Converters

## APPLICATION

- Extractive gas analysis
- Emission and process monitoring
- Continuous detection of liquids in the analysis system
- For protection of gas analysers against damage by inrush of liquids
- To switch off the sample gas pump or to switch a valve

## BENEFITS

- Safe condensate detection
- No electrode abrasion
- Long life time and availability
- Corrosion resistant
- Variable application possibilities
- Safe and reliable operation

## FEATURES

- 3 main components:
  - sensor KW-1
  - flow chamber KW-1A
  - electronic module KW-2E (wall mounting) resp. KW-2EB (rail mounting)
- Measurement with high frequency alternating voltage
- No depositions
- Sensor with platinum electrodes
- No galvanisation effects
- Adjustable sensitivity
- Sensor short-circuit detection
- Electronic module for rail or wall mounting
- 2 status change-over contacts
- Combined operation and status indication

## TECHNICAL DATA

Model	KW-1	KW-1A	KW-2E	KW-2EB
Description	sensor	flow chamber	electronic module	electronic module
Mounting	in KW-1A	wall mounting	rail mounting	wall mounting

### Operation

Ambient temperature	-25°C to +50°C (no frozen condensate)			
On time	100 %			
Flow rate	max. 1000 NI/hr			
Operation pressure	max. 3 bara			
Mounting position	vertical		any	

### Construction

Dimensions (B x H x T) [mm]	30 x 115 x 30		120 x 80 x 55	90 x 77,5 x 45
Weight	40 g	PVDF: 80 g SS: 350 g	250 g	150 g
Sample gas In / Out	G 1/4" i			
Sensor connection	compression fitting 12 mm			
Media wetted materials	glass, platinum	PVDF or SS316Ti		
Protection class			IP65	IP20
Cable glands				3 x PG7
Approvals / signs	CE			

### Electrics

Power supply			115 to 230 VAC 50 to 60 Hz or 24 VADC	
Power consumption			ca. 2 VA	
Adjustable threshold range			2 to 30 kΩ	
Fusing			lead fuse T500mA	
Sensor voltage			≤ 5 V	
Measuring frequency			approx. 7 kHz	
Alarm delay			0,5 s	
Switching hysteresis			approx. 10 kΩ	
Status relays			2 volt free change-over contacts	
Switching capacity status relay			230 VAC 2 A, min. 5 VADC 5 mA	
Diagnostic / operation indication			dual colour LED	
Connection terminals			spring type terminals 0,08 mm <sup>2</sup> to 2,5 mm <sup>2</sup>	
Connection cable	2 x 0,35 mm <sup>2</sup>			

# DIMENSIONS

Dimensions in mm

## Electronic module KW-2EB for wall mounting

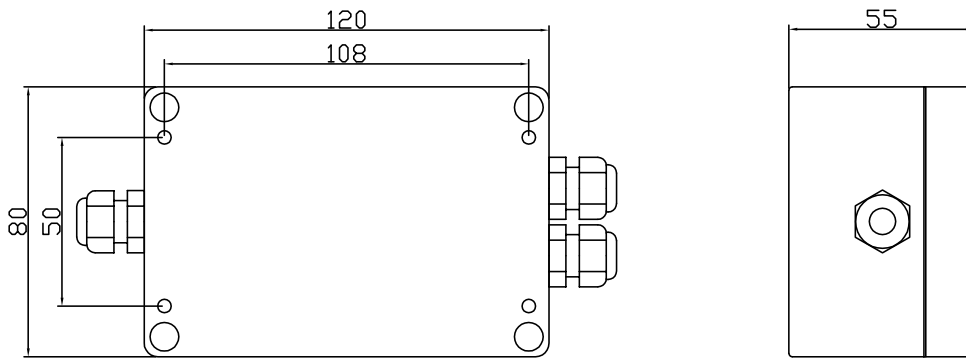

## Electronic module KW-2E for rail mounting

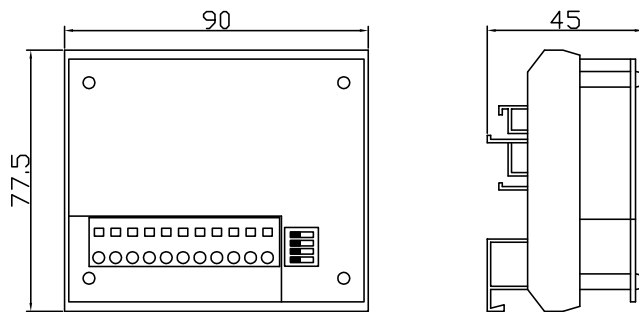

## Sensor KW-1

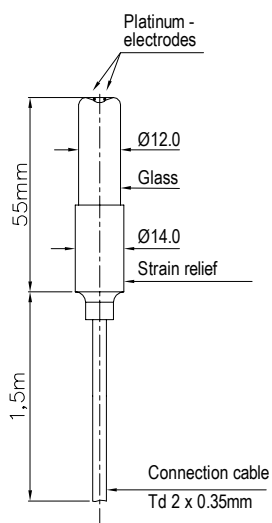

## Flow chamber KW-1A

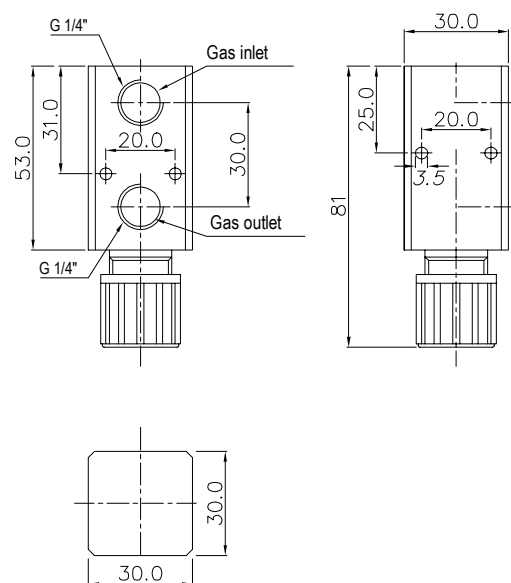

## DIMENSIONS

Dimensions in mm

### Sensor KW-1 mounted into flow chamber KW-1A

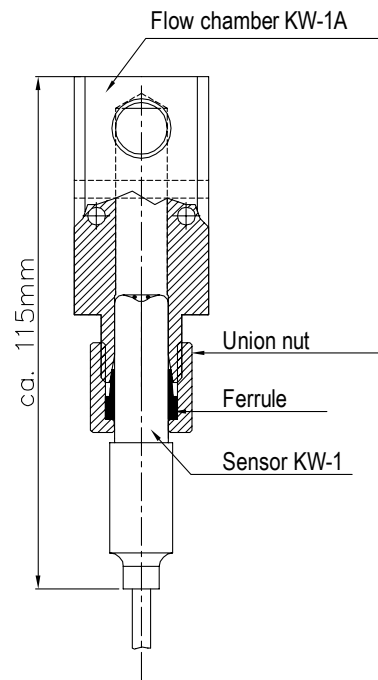

## ORDER CODE

Part number	Description
17.04000	KW-1 condensate sensor, platinum electrodes, 1,5 m connection cable, Ø 12 mm
17.04020	KW-1A flow chamber, 2 x G 1/4"i, 1 x compression fitting 12 mm, PVDF
K1221001	KW-1A flow chamber, 2 x G 1/4"i, 1 x compression fitting 12 mm, SS316Ti
17.04012	KW-2E electronic module for DIN-rail mounting, 115 to 230 VAC 50/60 Hz, 2 volt free change-over contacts
17.04013	KW-2EB electronic module for wall mounting, 115 to 230 VAC 50/60 Hz, 2 volt free change-over contacts
17.04016	KW-2E electronic module for DIN-rail mounting, 24 VADC, 2 volt free change-over contacts
17.04014	KW-2EB electronic module for wall mounting, 24 VADC, 2 volt free change-over contacts

Gas Sampling Probes

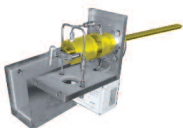

Heated Sample Lines



Sample Gas Coolers



Gas Conditioning Systems



NOx Converter



and solutions for

