



# JCM-310 and JCMF-310 Peltier Sample Gas Coolers

**JCT**  
Analysentechnik



Gas Sampling  
Probes

Heated Sample  
Lines

Sample Gas Coolers

Condensate  
Treatment

Accessories

Gas Conditioning  
System

Sample Gas  
Converters

## APPLICATION

- Extractive gas analysis
- Emission and process monitoring
- Continuous drying of sample gas to a precise low and constant outlet dew point
- Minimises water vapour cross sensitivities and volumetric errors

## BENEFITS

- Very powerful compact complete unit with condensate removal
- High flow rates of up to 250 NI/h
- Very low wash out ratios even at high water vapour concentrations in the sample gas
- High inlet dew points up to 80°C possible
- Reliable condensate separation even at very high ambient temperatures up to 50°C
- Extremely precise long-term stable dew point even under varying loads
- Maximum operational safety
- Low maintenance operation
- Easy to maintain design

## FEATURES

- Frame mounting for cabinets or wall mounting
- New heat exchanger JHEX-4 in different materials
- Intelligent digital control electronic
- Applicable up to an ambient temperature of 50°C
- Condensate pump as option
- Status contact for temperature thresholds as well as for condensate alarm
- Visual alerting via LEDs
- Self monitoring with deactivation of the external sample pump in case of alarm
- Ready for operation within less than 15 minutes

## TECHNICAL DATA

Model	JCM-310	JCM-312	JCMF-310	JCMF-312
Description of sample gas cooler	standard	high-performance	standard	high-performance
Cooling principle	peltier cooling			
Number of gas paths	1			
Number of peltier elements per active gas paths	1	2	1	2
Integrated condensate pump (option)	1		-	
<b>Operation</b>				
Gas flow per gas path*	max. 250 NI/hr			
Gas inlet temperature*	max. 140°C; SS heat exchanger: max. 180°C			
Gas inlet dew point*	max. 80°C			
Gas outlet dew point	+5°C (factory default); adjustable from +0,5°C to +7,5°C			
Dew point stability (for constant inlet conditions)	±0,1K			
Ambient temperature	+5° to +40°C	+5° to +50°C	+5° to +40°C	+5° to +50°C
Cooling capacity total	max. 15 W	max. 30 W	max. 15 W	max. 30 W
Operating pressure with condensate pump	0,2 to 2,2 bara		-	
Max. operating pressure without condensate pump	4,0 bara; SS heat exchanger: max. 19 bara			
Ready for operation	< 15 min			
Pressure drop at max. flow rate	3 mbar			
<b>Construction</b>				
Dimensions over all (W x H x D)	289 x 308 x 140 mm		180 x 340 x 205 mm	
Installation	wall mounting		frame mounting	
Mounting position	horizontal			
Weight**	approx. 9,3 kg		approx. 9,3 kg	
Housing / Colour	stainless steel / natural			
Gas wetted materials (depending on configuration)	aluminium coated, PVDF, 1.4571, FFKM, Duran glass			
Dead volume per gas path	67 ml			
Connection sample gas and condensate outlet with/for condensate pump	PVDF-hose fitting DN 4/6			
Condensate outlet without condensate pump	1/4"NPTf or 3/8"NPTf			
Approvals / signs	CE			
<b>Electrics</b>				
Power supply	230 VAC 50/60 Hz +/- 10 % or 115 VAC 50/60 Hz +/- 10 %			
Power consumption (depending on load and ambient temperature)	30 to 160 VA			
Connection power	2 x cable conduit M12		external PCB	
Protection class (in default mounting position)	IP 54 (EN 60529)		IP 54 (EN 60529) PCB: IP 00 (EN 60529)	
Fusing	lead fuse T2A			
On time	100 %			
Diagnostic / operation indicator	1 x bicolour-LED			
Status threshold	< 0 / > +10°C			
Status delay	0,5 s			
Status relay	volt free contact, 230 VAC / 2 A, min. 5 VADC / 5 mA			
Connection terminals / clamping range	spring type terminals 0,5 mm <sup>2</sup> to 2,5 mm <sup>2</sup>			

\* Results from the effective cooling capacity at 20°C ambient temperature and 5°C outlet dew point and can be influenced by further operational parameters

\*\* Dependent on configuration

## TECHNICAL DATA

**Outlet dew point in dependence on the ambient temperature JCM-312 / JCMF-312**

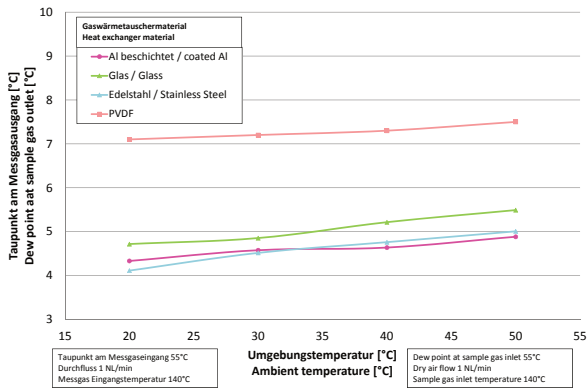

**Outlet dew point in dependence on the inlet dew point JCM-312 / JCMF-312**

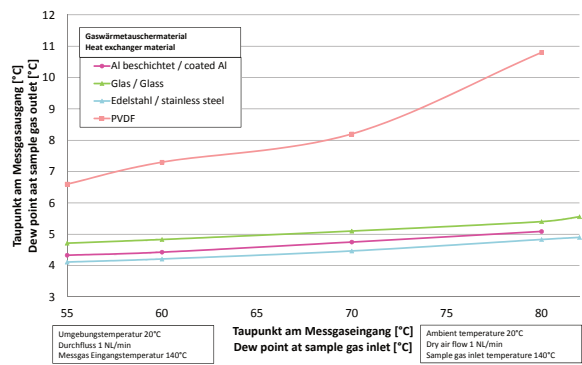

## DIMENSIONS

Dimensions in mm

**JCM-310**

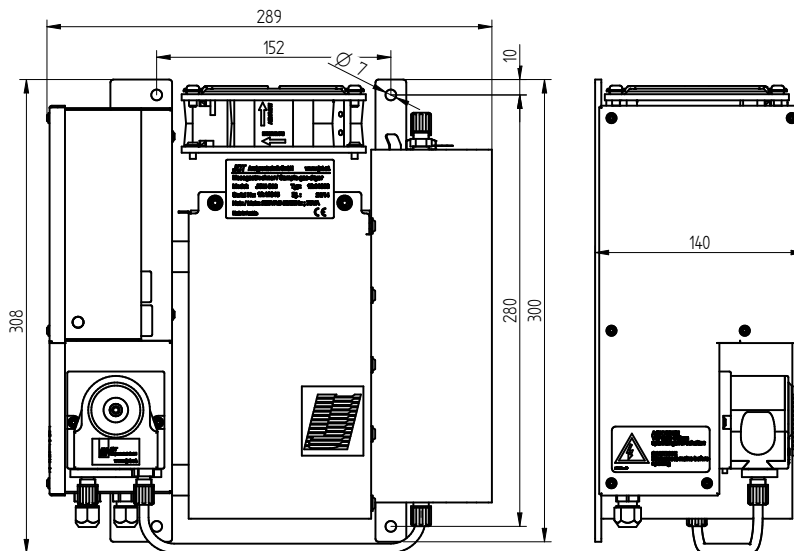

**JCMF-310**

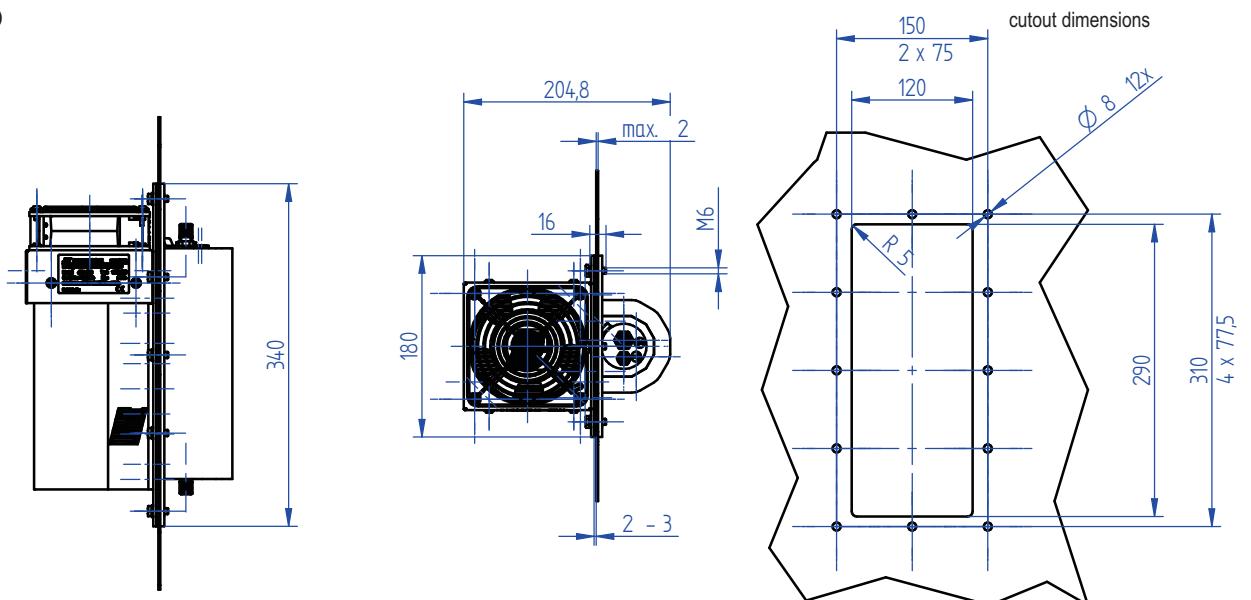

## GAS FLOW DIAGRAMS

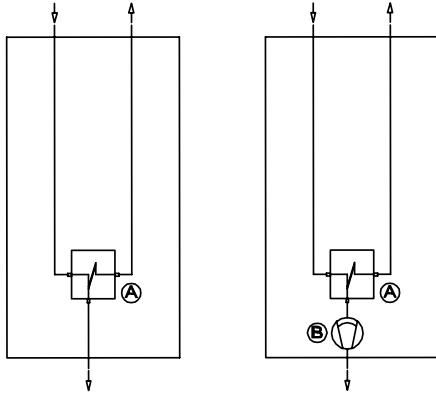

- A Actively cooled heat exchanger optionally with one or two peltier elements
- B Condensate pump (option)

## ORDER CODE

### JCM-310 series

Performance	standard	0.	
	high-performance	2.	
Heat exchanger	JHEX-4 heat exchanger aluminium coated	1	
	JHEX-4 heat exchanger PVDF	2	
	JHEX-4 heat exchanger Duran glass	3	
	JHEX-4 heat exchanger stainless steel	4	
Condensate pumps	with condensate pump JSR-25		1
	without condensate pump JSR-25, 1/4" NPTf Outlet		2
	without condensate pump JSR-25, 3/8" NPTf Outlet		3
Power supply	230 VAC 50/60 Hz		A
	115 VAC 50/60 Hz		B

Order code

**JCM-31**        

### JCMF-310 series

Performance	Standard	0.	
	high-performance	2.	
Heat exchanger	JHEX-4 heat exchanger aluminium coated	1	
	JHEX-4 heat exchanger PVDF	2	
	JHEX-4 heat exchanger Duran glass	3	
	JHEX-4 heat exchanger stainless steel	4	
Condensate outlet	PVDF-hose fitting DN 4/6		1
	1/4" NPTf Outlet		2
	3/8" NPTf Outlet		3
Power supply	230 VAC 50/60 Hz		A
	115 VAC 50/60 Hz		B

Order code

**JCMF-31**        

Gas Sampling Probes

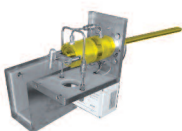

Heated Sample Lines



Sample Gas Coolers



Gas Conditioning Systems



NOx Converter



and solutions for

